

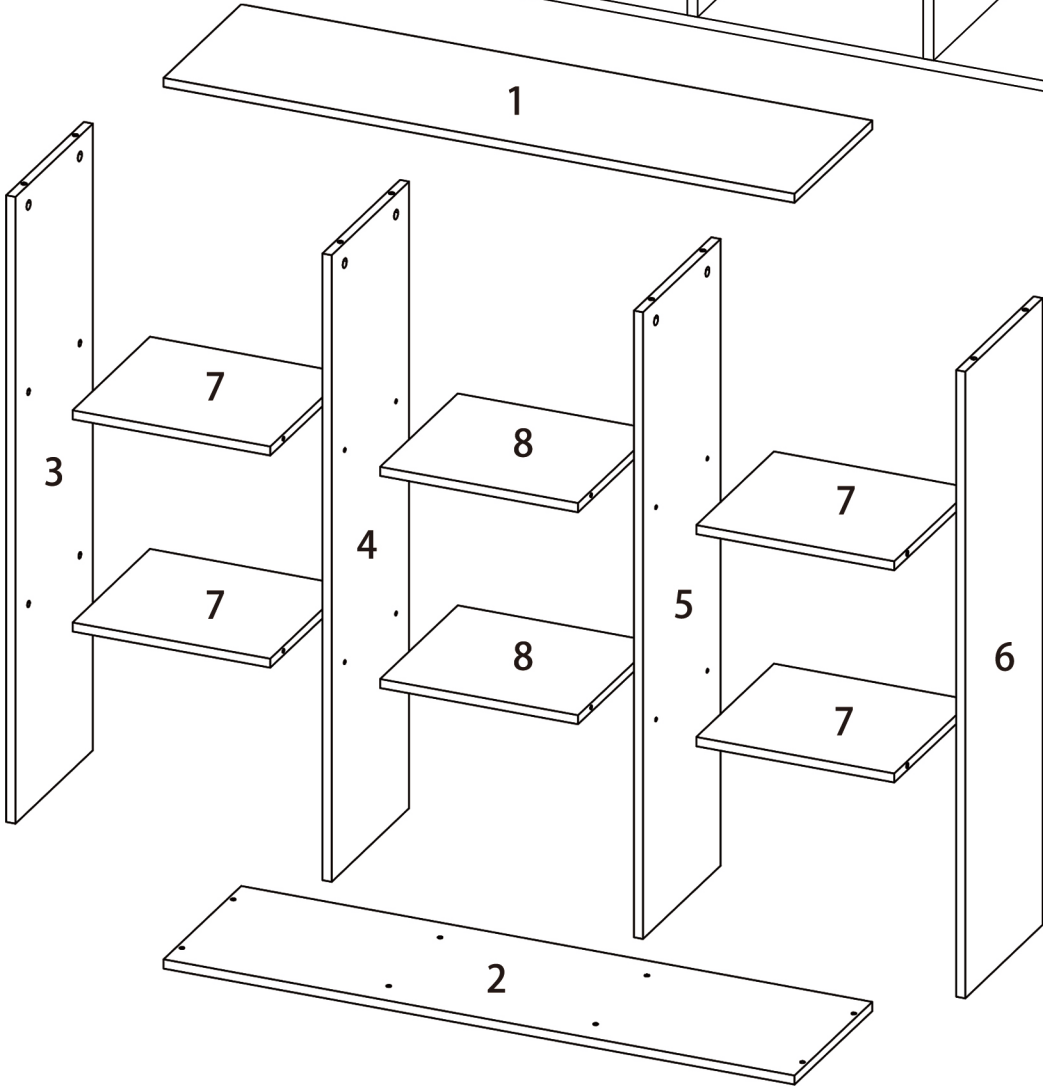

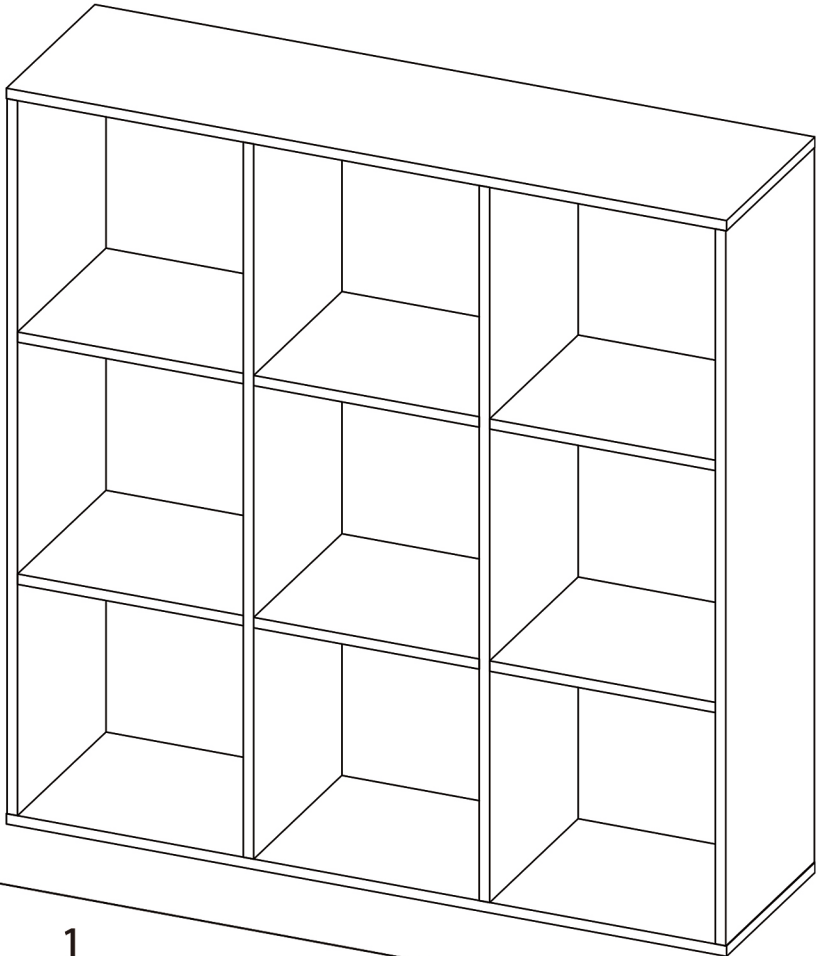



Assembly Instruction

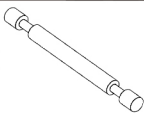

Accessories list

	Parts	Specification	Carton	Pcs		Parts	Specification	Carton	Pcs
A		6×40	1/1	X 16	B		15×11	1/1	X 32
C		5×60	1/1	X 8	E		M3.5×14	1/1	X 5
F		M5×40	1/1	X 8	G		10×Φ40	1/1	X 5
		21mm	1/1	X 32					

Company: (mm)

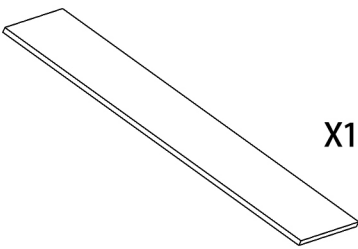
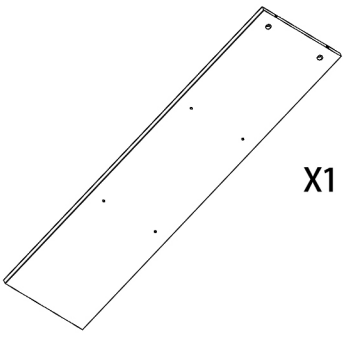
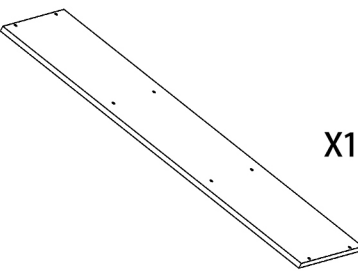
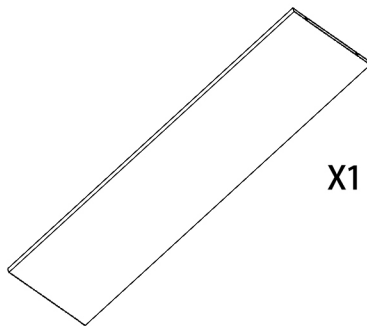
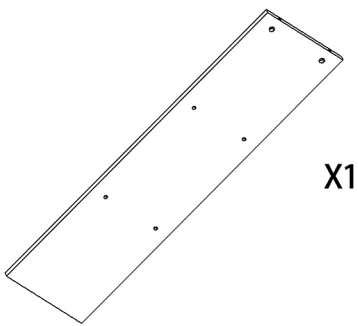
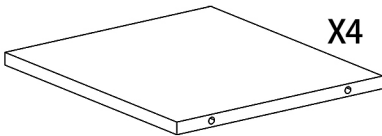
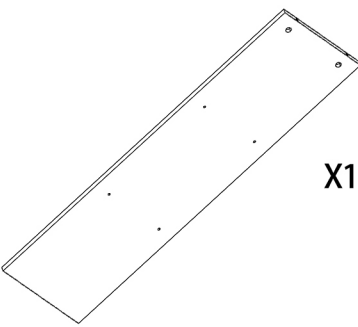
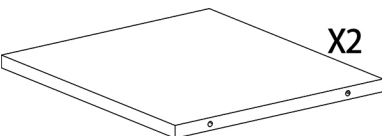
1	 X1	1040x290	1/1	5	 X1	1040x290	1/1
2	 X1	1040x290	1/1	6	 X1	1040x290	1/1
3	 X1	1040x290	1/1	7	 X4	326x290	1/1
4	 X1	1040x290	1/1	8	 X2	326x290	1/1

1

Installation method of three in one rod and buckle

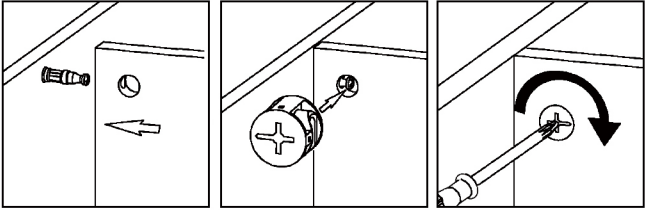
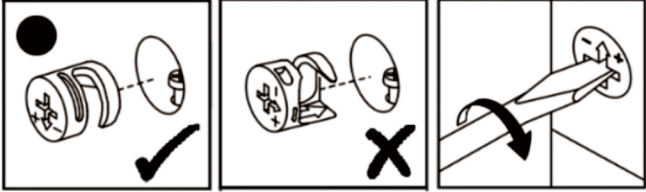
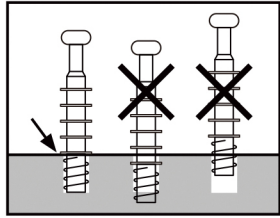

2

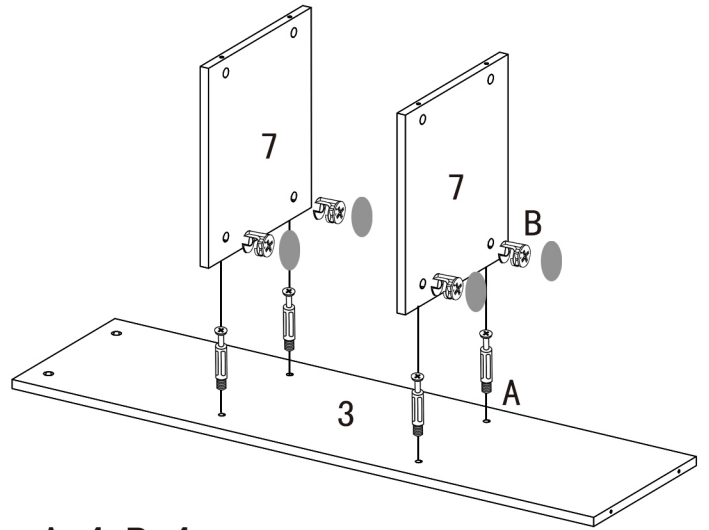

Ax4 Bx4

3

Part B connected to accessory C first rotate 90 degrees

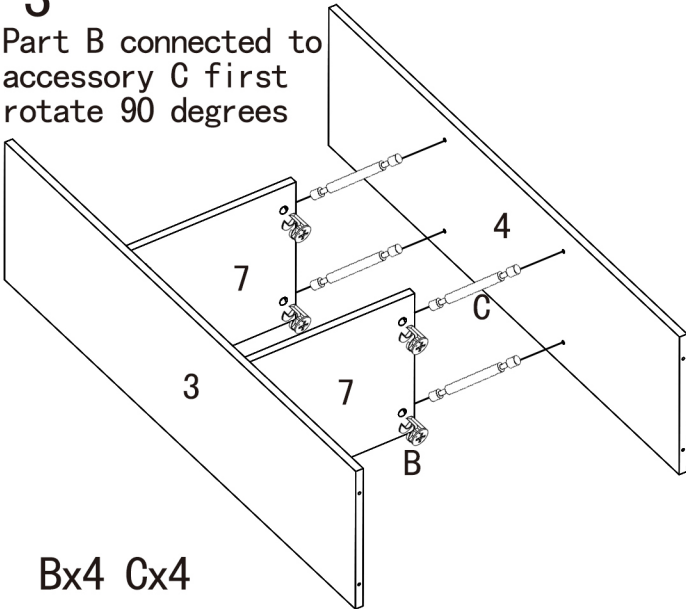

Bx4 Cx4

4

Part B connected to accessory C first rotate 90 degrees

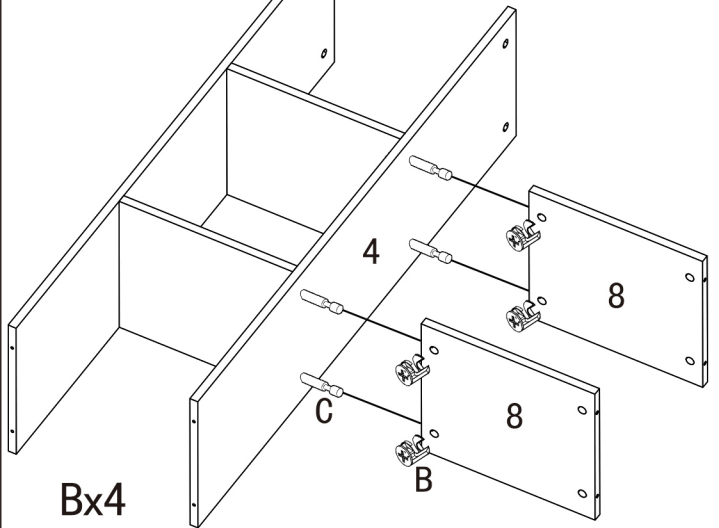

Bx4

5

Part B connected to accessory C first rotate 90 degrees

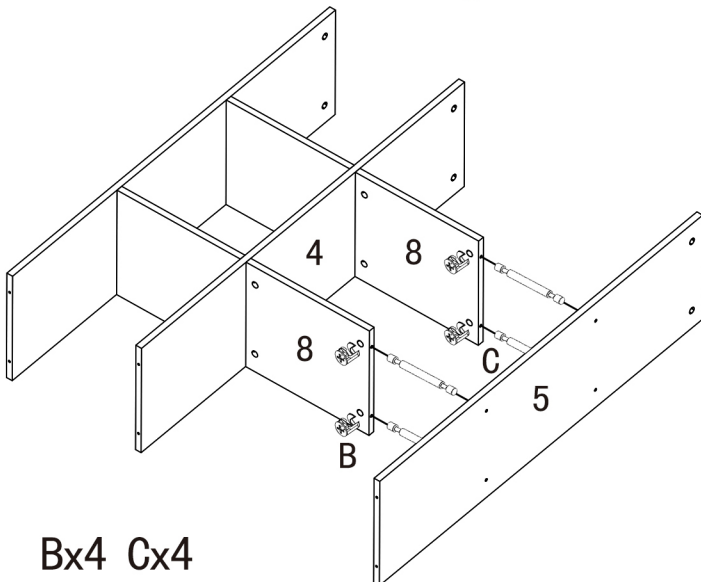

Bx4 Cx4

6

Part B connected to accessory C first rotate 90 degrees

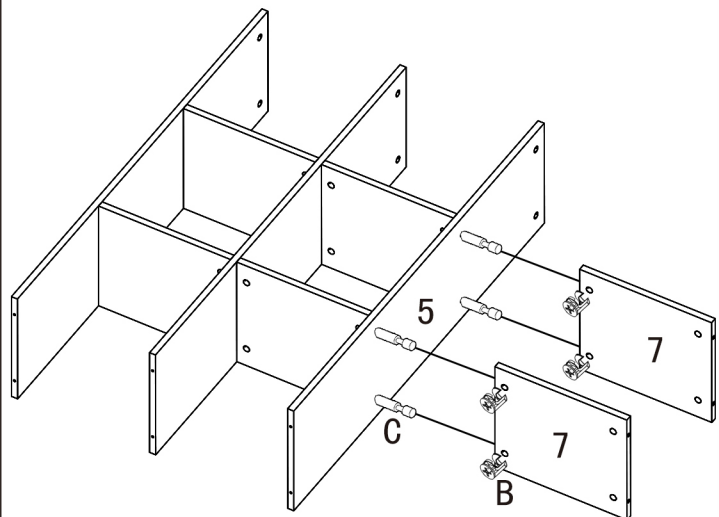

Bx4

7 Now tighten the B fitting connected to the fitting C

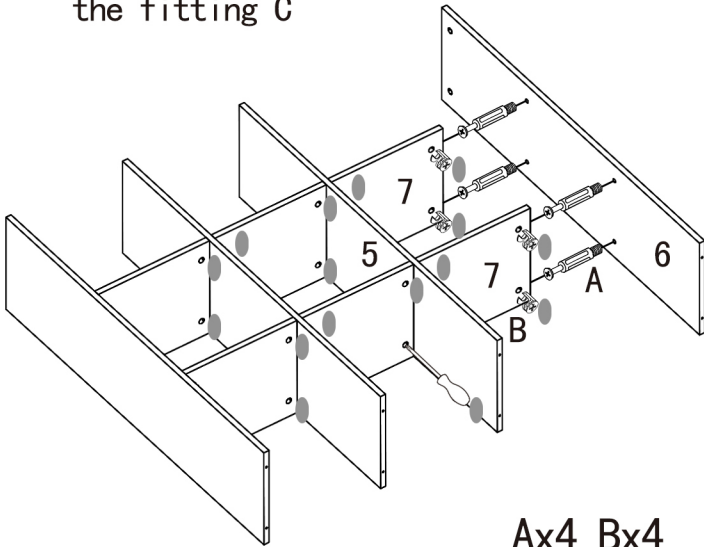

Ax4 Bx4

8

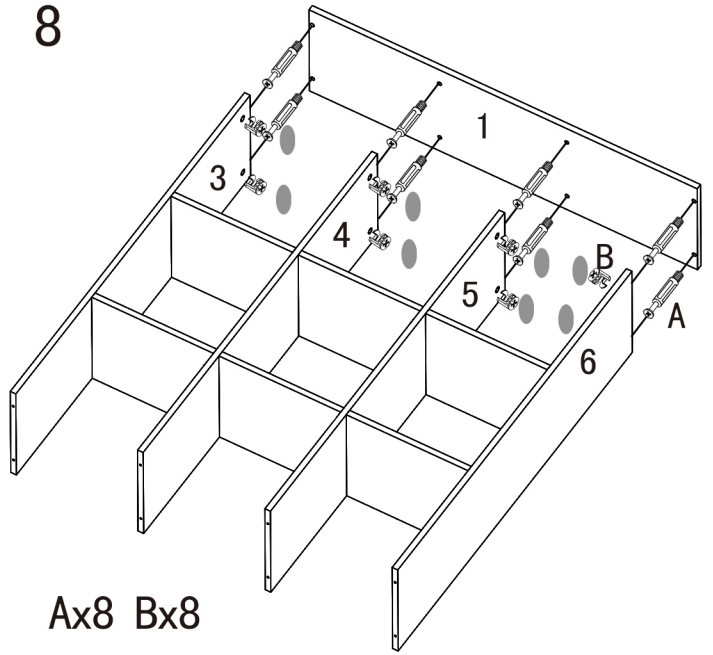

Ax8 Bx8

9

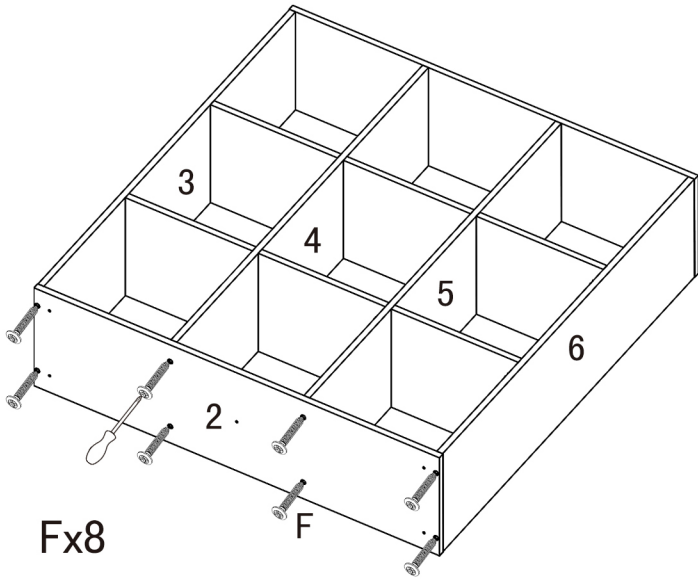

Fx8

10

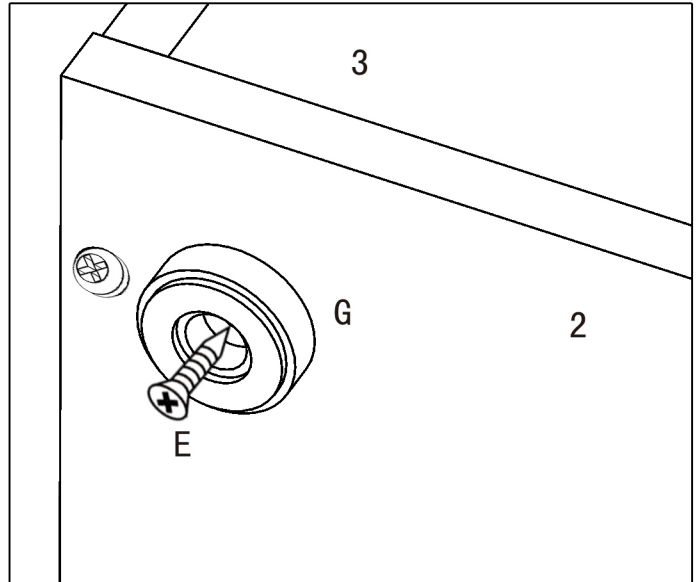

11

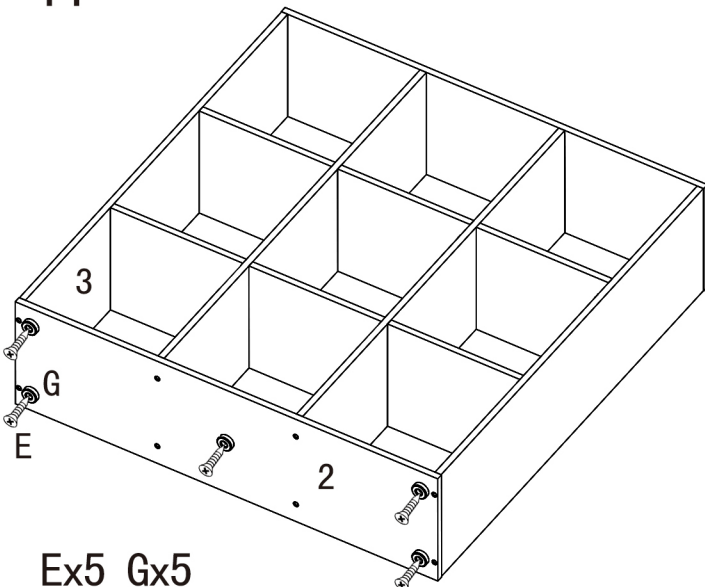

Ex5 Gx5

12

